



4G Mobile HomePhone

Operator's Manual

Table of Contents

Safety Information	3
Overview of the phone	6
Quick Setup Guide	7
Quick User Guide	10
EasyCall	14
Phone Dialler.....	15
Call History.....	17
Contacts	18
Messaging.....	27
Blacklist.....	36
Clock	38
Calculator	41
Sound Recorder	41
SOS – Emergency Call	43
Settings	45
Settings – Connections	45
Settings – Customisations.....	48
Settings – System	52
Troubleshooting and support.....	55

The Bluetooth® word mark and logos are registered trademarks owned by Bluetooth SIG, Inc. and any use of such marks by 3 Feet Solutions Pty Ltd is under license. Other trademarks and trade names are those of their respective owners.

Safety Information

Welcome to Opel Mobile and thanks for purchasing our products. For the best performance, we recommend you read this manual carefully, especially the "safety instructions". This will take you a few minutes, but it will save you time later and will allow you to enjoy all the features on your device.

THIS MODEL MEETS INTERNATIONAL GUIDELINES FOR EXPOSURE TO RADIO WAVES

Your mobile device is a radio transmitter and receiver. It is designed not to exceed the limits for exposure to radio waves recommended by international guidelines. These guidelines were developed by the independent scientific organization ICNIRP and include safety margins designed to assure the protection of all persons, regardless of age and health.

The guidelines use a unit of measurement known as the Specific Absorption Rate, or SAR. The SAR limit for mobile devices is 2 W/kg and the highest SAR value for this device when tested on the body is 1.641 W/kg*.

As SAR is measured utilizing the devices highest transmitting power the actual SAR of this device while operating is typically below that indicated above. This is due to automatic changes to the power level of the device to ensure it only uses the minimum level required to reach the network.

The World Health Organization has stated that present scientific information does not indicate the need for any special precautions for the use of mobile devices. They note that if you want to reduce your exposure then you can do so by limiting the length of calls or using a hands-free device to keep the device away from the head and body.

Additional Information can be found on the website of the World Health Organization

**The tests are carried out in accordance with international guidelines for testing.*

***For body worn operation, this phone has been tested and meets the RF exposure guidelines when used with the Opel Mobile accessories supplied or designated for this product. Use of other accessories may not ensure compliance with RF exposure guidelines*

How to handle and preserve your device?

- Trying to modify, disassemble or repair the device or the charger yourself will make the warranty invalid. Only certified repairers may install or repair phone equipment.
- Avoid hitting or shaking your phone.
- The warranty of this phone may be annulled if you use unauthorised accessories. To prevent this from happening and to keep your phone working properly use only the battery charger and Micro USB cable that originally comes with the device.
- Make sure the device does not get wet. To avoid possible, short-circuit, electric shock or corrosion keep your phone away from rain, water splash, sweat or moisture. You must not use your device with your hands wet or immerse it in water. In case it gets wet keep the phone off and do not try to use a microwave to dry it.
- Do not use your phone when entering areas that are near flammable liquids.
- Observe all local laws and regulations on the use of mobile phones. Turn off the device before entering petrol stations, oil refineries or chemical plants.
- This product should not be used in extremely hot, cold, dusty, or humid spaces. It also should not be exposed to long periods of sunshine or strong magnetic fields.
- If you have a pacemaker keep the phone at least a 20cm distance from the place it is located. This phone may cause interference to some hearing aids and other electronic devices.
- Avoid all heat sources, ovens or other appliances (including amplifiers) that produce heat or have hot surfaces.
- Switch off the phone when entering an aircraft.
- Do not use a hand-held phone when operating any motor vehicles, heavy equipment or moving objects.
- Excessive high-volume levels or noise may affect your hearing. To prevent this from happening use an adequate volume in your earphones when you are listening to music or employing any of the multimedia features on the phone.
- You are fully responsible for keeping your information backed up and we do not take any legal responsibility for data that is damaged or lost. It is possible to erase or interfere with the information stored in your phone by a magnetic device when using your phone. To avoid this issue, keep your phone clear from magnetic devices.
- Pointing the torch into your own or another person's eyes will cause damage and may result in blindness.

Safety recommendations for accessories

- Use only Opel Mobile accessories or chargers that came with this phone.
- Be careful when handling the battery. The lithium-ion battery can be put into use immediately after being unpacked. Use only the Opel Mobile battery that came with the device. We recommend charging the battery as soon as possible once the phone has been switched on.
- **CAUTION: RISK OF EXPLOSION IF BATTERY IS REPLACED BY AN INCORRECT TYPE. ENSURE YOU ALWAYS ONLY USE THE OPEL MOBILE BATTERY THAT IS SPECIFIED FOR THIS DEVICE. DISPOSE OF USED BATTERIES ACCORDING TO THE INSTRUCTIONS.**
- Immediately stop using the battery charger if you smell an odour or overheats or a crack or swelling appears in the casing.
- In case you notice the cable, or the plug have suffered any damage, discontinue using it and contact Opel Mobile support line as soon as possible for advice.
- The optional memory card should be protected from strong shocks and static electricity. Handle with care.

Usage conditions and restrictions

- All packaging materials, especially plastic ones, must be disposed of properly. The lack of this procedure may cause a suffocation danger to children. Any packaging must be kept out of children's reach.
- This device is not a toy and not designed for children and strict adult supervision must be adhered to at all times. Keep the phone and the accessories beyond children's reach.
- This device can be recycled. To dispose of this device properly remember to follow local regulations. Local authorities may guide you on finding appropriate facilities to this end. The battery must never be disposed of in a fire.
- If this phone is lost or has been stolen, please notify your network service provider as soon as possible and ask for the SIM card to be deactivated.
- You are fully responsible for any damage caused by not following these instructions or for improper use of the device. We do not accept any liability for any improper use or mishandling on this device.
- In any event we are not liable for any direct or indirect personal injury or death liability damages due to the performance of the device or the Telecommunication service, if your device is not working as its intended, we recommend you stop using it immediately and contact customer support.
- This device is not intended to be a life saving device; If you are in a life-threatening medical emergency, we recommend you call emergency 000 immediately.

Overview of the phone

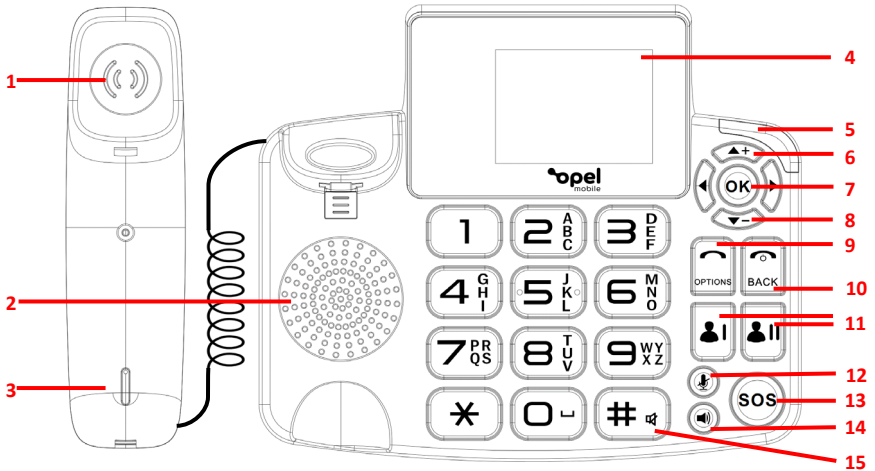

Numbers	Descriptions
1	Handset earpiece
2	Speaker
3	Handset mic
4	Colour display
5	Notification LED light
6	Volume up / Cursor button
7	OK button
8	Volume down / Cursor button
9	Answer / Options button
10	End call / Back / Power button
11	EasyCall I and II buttons

12	Mute button
13	SOS button (press 3 times in quick succession)
14	Speakerphone button
15	Silent mode button (long press at the home screen)

Quick Setup Guide

1. Unpack all the contents out of the packaging and have your SIM card/s ready to be inserted into the main unit.
(Please note this phone supports both standard SIM and nano SIM card/s, if you do not have either of them, please contact your SIM card provider as they will be able to supply one for you)
2. Connect the handset to the main unit using the handset cord provided.
3. Remove the back cover from the main unit.

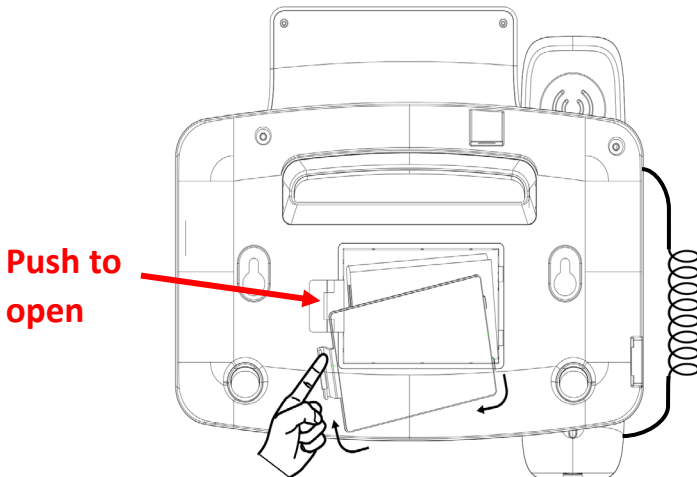

4. Remove the battery from the main unit by lifting from the top and pulling out.
5. Insert your SIM card/s into either one or both SIM trays according to its size.

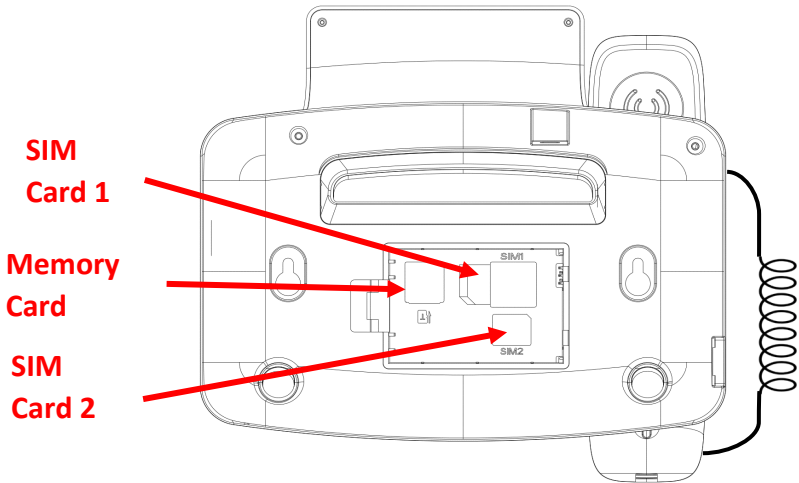

For **SIM1**, slide a **standard SIM card** in to the right until it doesn't go in any further. Please ensure the gold plates are facing downwards and the cornered edge is in the lower left corner.

For **SIM2**, first slide the SIM tray door to the right and put a **nano SIM card** in, and then slide the SIM tray door to the left. Please ensure the gold plates are facing downwards and the cornered edge is in the upper right corner.

6. If you wish to insert an optional SD/TF memory card for extra phone storage, insert it into the memory card slot, ensure the gold plates are facing downwards when inserting it into the phone.
7. Re-insert the battery back into the main unit. Ensuring the gold plates on the battery and the main unit are aligned
8. Replace the back cover, push it down until it has clicked into place.
9. Connect the power adapter to the main unit's charge port located at the rear of the main unit using the Micro USB cable provided.

**Micro USB
charging port**

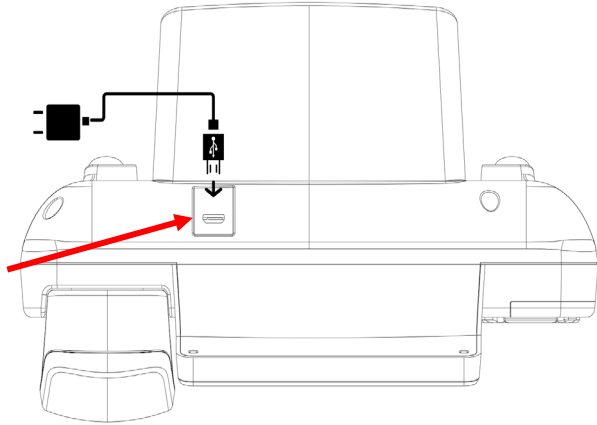

Turning the phone on for the first time

After connecting the power adapter, turn the phone on by holding down the Power button.

The phone will begin to boot, once finished booting, your phone is ready to be used. If your SIM card is inserted and is active, the time and date will be automatically set based on your location.

Powering the Device on and off

1. To power the device on hold down the Power button for 3 seconds.
2. To turn the phone off, long press the Power button for 3 seconds and select Power Off to confirm.

Quick User Guide

Answer a call

To answer an incoming call, lift up the handset or press the green Answer button and the call will be answered.

End a call

To end a call, put the handset back to the main unit, or press the red End Call button.

Reject an incoming call

To reject an incoming call, press the red End Call button.

Silence an incoming call

To silence an incoming call, press the Volume Up or Down button.

Quick adjust Ringtone volume

While at home screen, press the Volume Up or Down button to adjust the ringtone volume.

Notification LED light

Red – blinking: Charging

Red – steady: Charging is completed

Green – blinking: Incoming call ringing

Green – steady: Missed call

Blue – steady: Unread messages

Dialling and using keypad numbers (123 mode)

1. To dial a phone number, press the numeric buttons on the keypad and then press the green Answer button, or wait for 4 seconds and the phone will dial the number automatically.

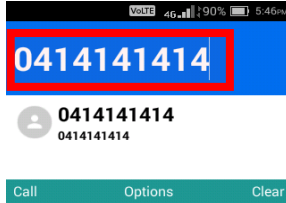

2. To type numbers while creating a contact or writing a message, press the “Hash” # button or long press the OK button for 2 seconds until “123” Number mode appears.

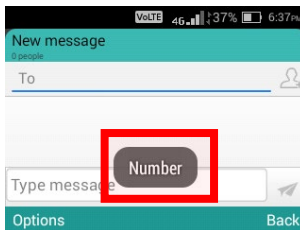

Typing Letters (EN/Abc modes)

1. To type in letters, long press the OK button for 2 seconds to choose between EN (Word), Abc (Letter) and 123 modes
2. EN is the predictive text mode. (see predictive text below)
3. Abc is standard letter modes e.g. when in this mode to type the letter “c”, press the “2 ABC” button 3 times until the letter “c” comes up.

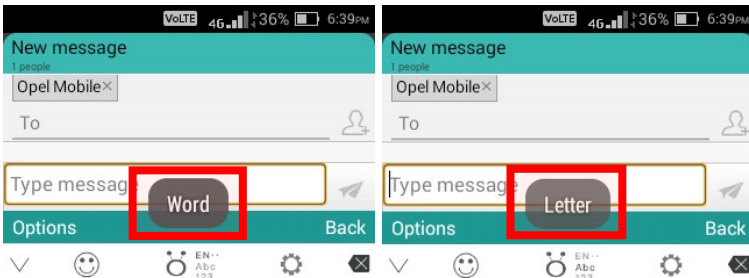

Predictive text (EN mode)

Predictive text is a smart way to type messages. This feature can make typing easier by suggesting words based on what you are typing.

1. Use the keypad to type the word without pressing the same button multiple times e.g. To type “hello”, press the “4, 3, 5, 5, 6” buttons once and the word “hello” will show up for selection. It also suggests other word options like what has been typed in.
2. To choose another candidate word, use the cursor keys to highlight it and then press the “OK” button or the “Space” 0 button to select the word.

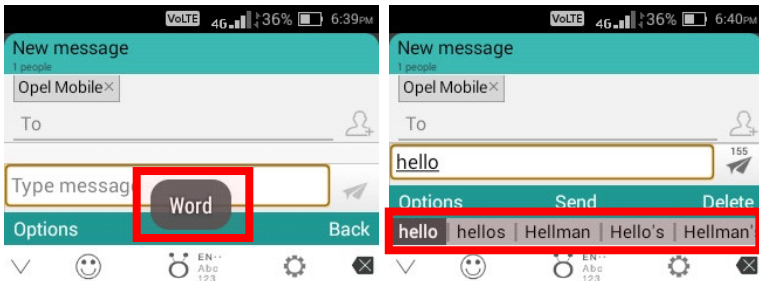

Symbols

To add symbols like full stop, comma, question mark, etc., press the “Star” * button and scroll using the cursor buttons to choose the symbol you wish to use. Or you can press “1” button to select the most commonly used symbols. Confirm your selection with the “OK” button.

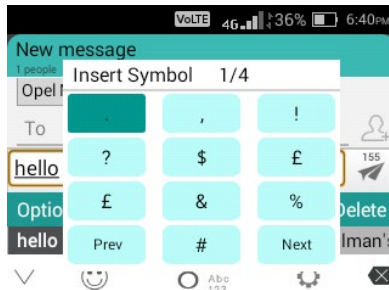

Smileys / Emojis

To add Smileys / Emojis, use the cursor buttons to choose the Smiley icon on the status bar. Confirm your selection with the “OK” button.

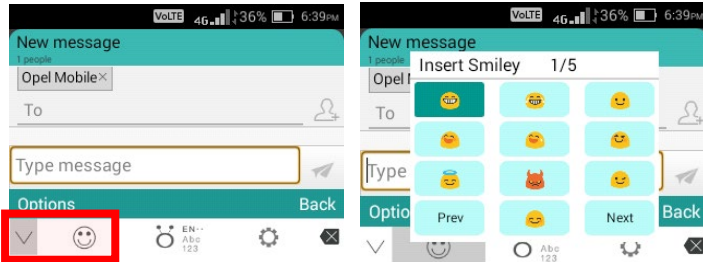

EasyCall

You can have 4 EasyCall contacts to make it easier to contact your most common or regular contacts.

1. To set up an EasyCall contact, while at the home screen press the left cursor button. Using the cursor buttons to highlight an EasyCall position and press the OK button to open the contact list, highlight the contact you want to choose and press the OK button to add.

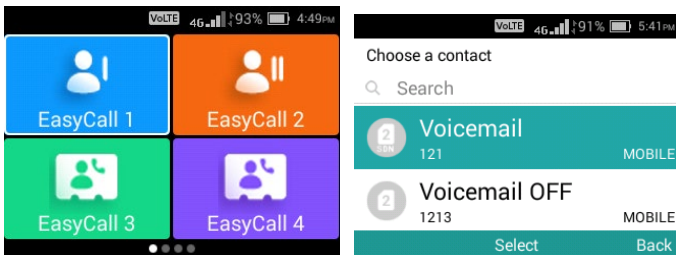

2. To delete an EasyCall contact, highlight the EasyCall contact, long press OK button and then confirm to Remove Contact.

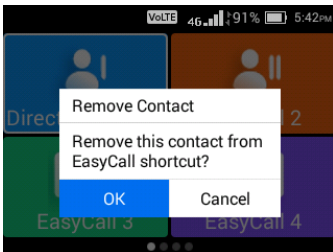

3. To dial an EasyCall contact, highlight the contact using the cursor buttons and press the OK button once, the phone will then attempt to dial that contact.
4. You can also use the EasyCall I and II buttons on the keypad to dial their numbers directly.

Phone Dialler

Press the green Answer button, or simply start dial a phone number to access the phone dialler.

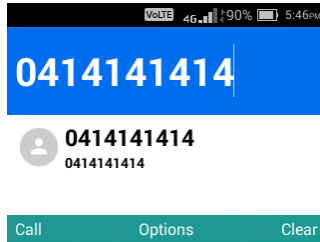

To add the current number to Contacts, press the OK button to open the option menu and select “Add to Contacts”.

To send a message to the current number, press the OK button to open the option menu and select “Send message”.

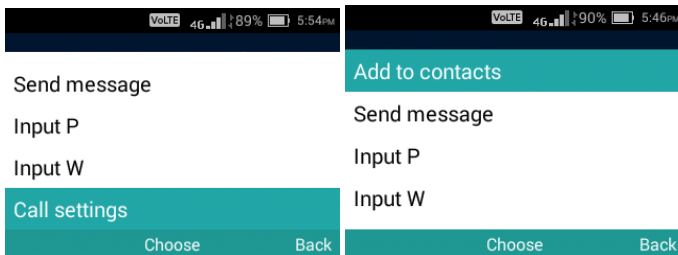

Call Settings

SIM card settings – Here you can setup the voicemail number, Fixed Dialling (FDN), Call Forwarding, Call Barring, Call Waiting and Caller ID Display.

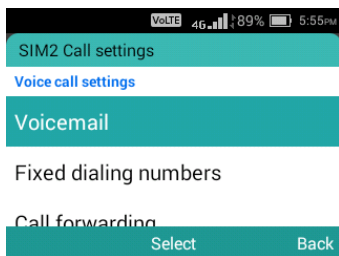
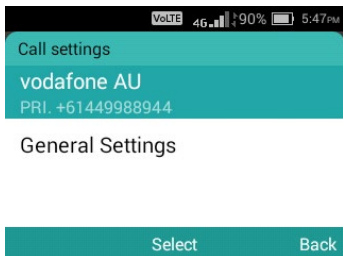

1. Within **Call Forwarding** you can select to always forward calls, forward when busy, forward when unanswered and forward when unreachable. Select the options you wish to use and turn them on. You can then choose which number you wish callers to be forwarded to. The default number will be your sim providers voicemail service.
2. Within **call barring** you can select to bar certain calls such as all outgoing calls, international outgoing calls, International outgoing home calls, all incoming calls, incoming calls while roaming and cancel all options. Select the options you wish to use.
3. Within **additional settings** you can adjust the caller ID settings and call waiting options.

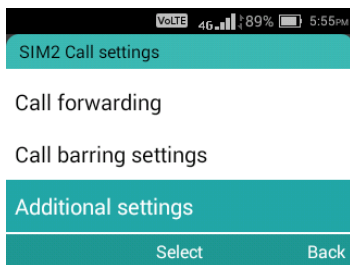

General settings – Here you can turn on or off Automatic Call Recording, Prompts for call connection, Fade-in ringer and Quick SMS responses when busy.

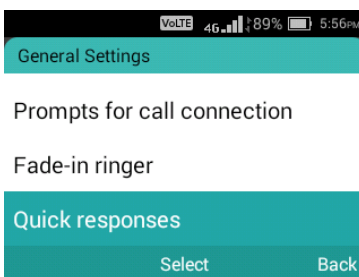
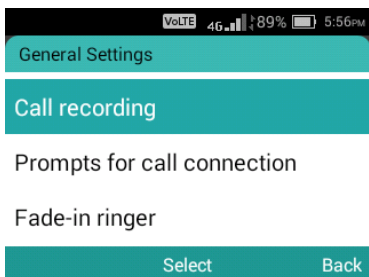

Call History

To access call history, use the cursor buttons to select the Call History icon and press the OK button to select it. Here you can view all your previous call records.

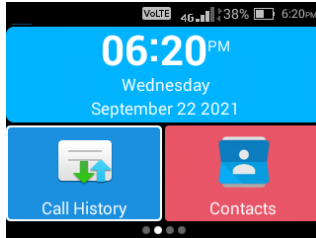

Dial a call from call history

To dial a call from the call history menu, highlight the person you want to call and press the green Answer button to bring up the Options menu, and then select “Call” menu item. You also can use the left and right cursor buttons to filter Missed / Outgoing / Incoming calls.

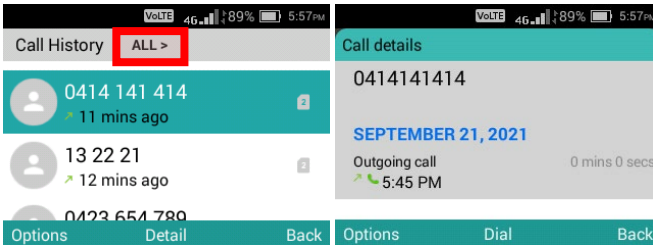

Call history menu options

To access the call history menu options, click the green Answer button to bring up the Options menu. Here you will be able to add as a new contact, add to existing contact, call, add to blacklist, clear call logs.

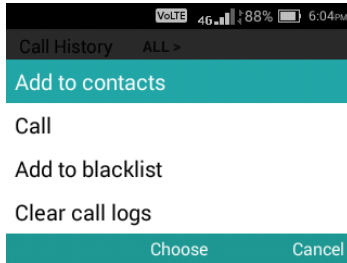

1. **Add to contacts** – You can create a contact with the highlighted phone number, or add it to an existing contact.
2. **Call** – Press the green Answer button to dial the number which is being highlighted.
3. **Add to blacklist** – Add the highlighted phone number to blacklist, so that this number cannot call or send messages to you.
4. **Clear call logs** – Click the OK button for selecting multiple items to delete.

Contacts

To access phone book, press OK button on the Contacts icon from the home screen.

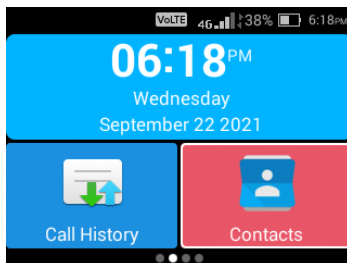

Adding a contact

1. To add a contact, press the Options button and press the OK button on Add Contact.

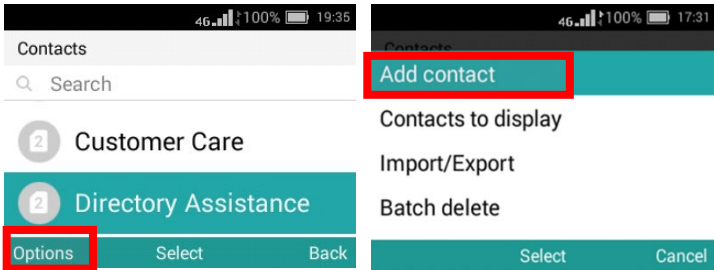

2. Enter in the contacts details. Then press the Options button and the OK button to save this contact.

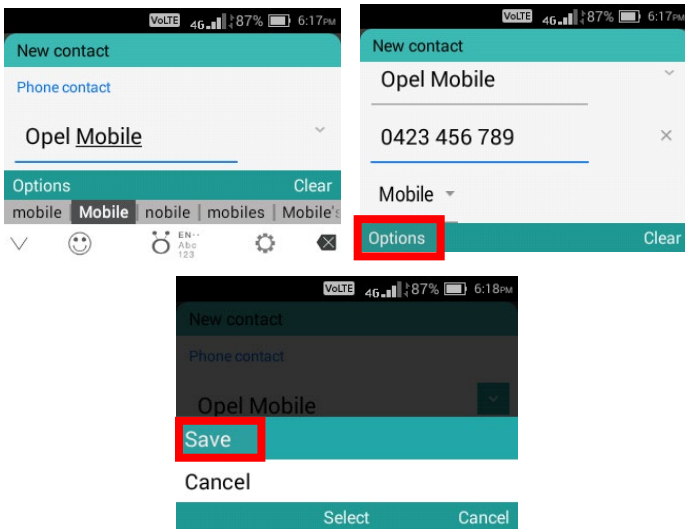

Edit a contact

1. To edit a contact, highlight the contact using the cursor buttons. Press the OK button to view the details, and then press the Options button and select "Edit" to edit it.

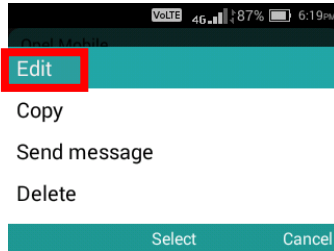
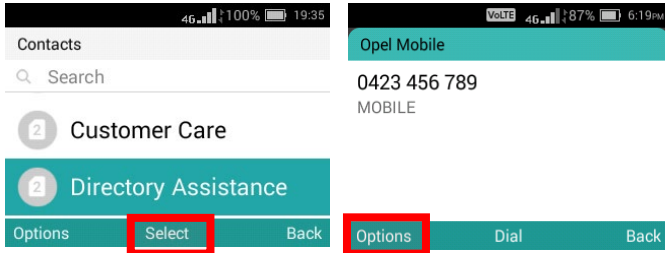

2. Once complete press Options button and OK button to save this contact.

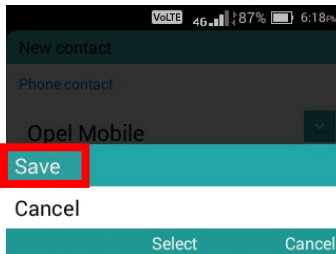

Delete a contact

To delete a contact, highlight the contact using the cursor buttons. Press OK button to view the details, and then press Options button and select “Delete” to delete it.

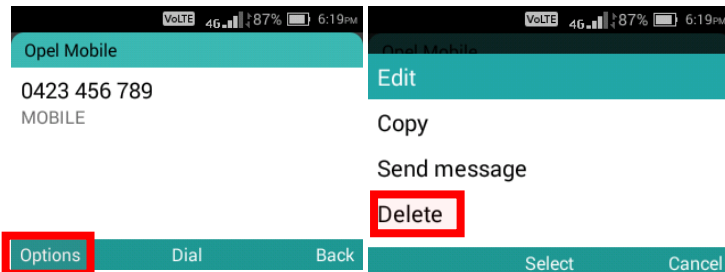

Searching contacts

To search for a contact, move the cursor to the search box at the top by using the cursor buttons, then type in the name of the contact you wish to find. It will then show you contacts with that name.

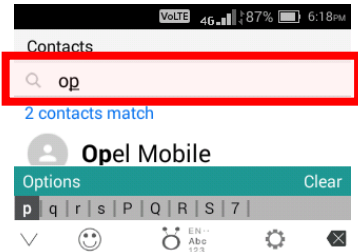

Calling and Messaging Contacts

1. To call or message a contact, highlight the contact using the cursor buttons. Press the OK button to view the details, and then press the OK button to call.

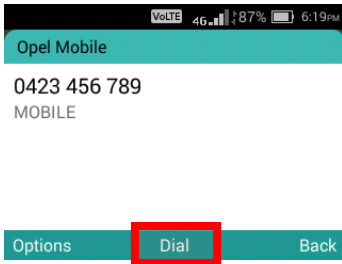

2. Or press the Options button and select "Send Message" to send a message.

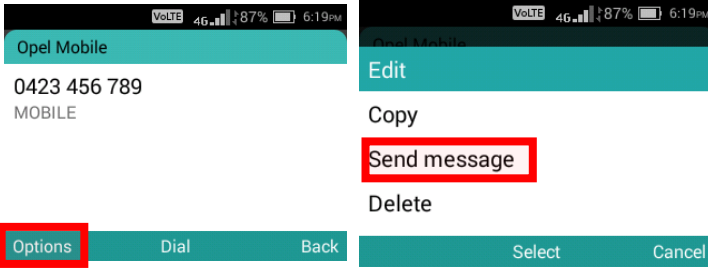

Add a contact to blacklist

To add a contact to blacklist, highlight the contact using the cursor buttons. Press OK button to view the details, and then press Options button and select “Add to blacklist”.

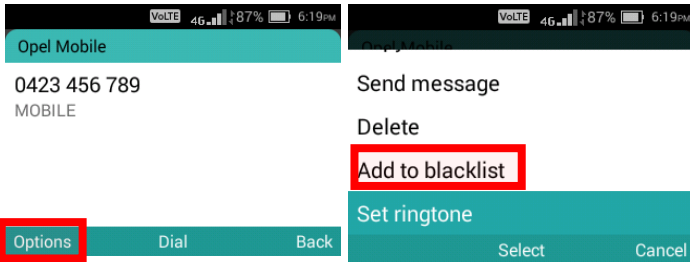

Assign a ringtone to a contact

To assign a ringtone to a contact, highlight the contact using the cursor buttons. Press OK button to view the details, and then press Options button and select “Set ringtone”.

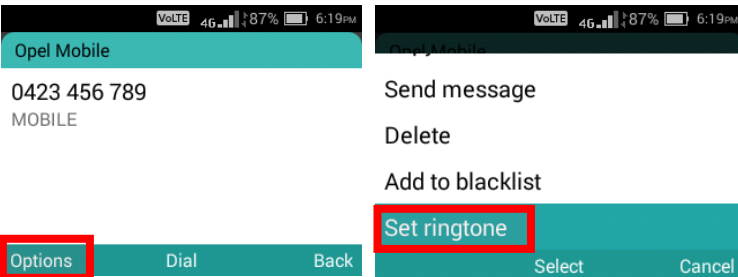

Contacts to display

To select contact types to display, press the Options button and press the OK button on “Contacts to display”. You can adjust to view all contacts or customise on what contacts to display.

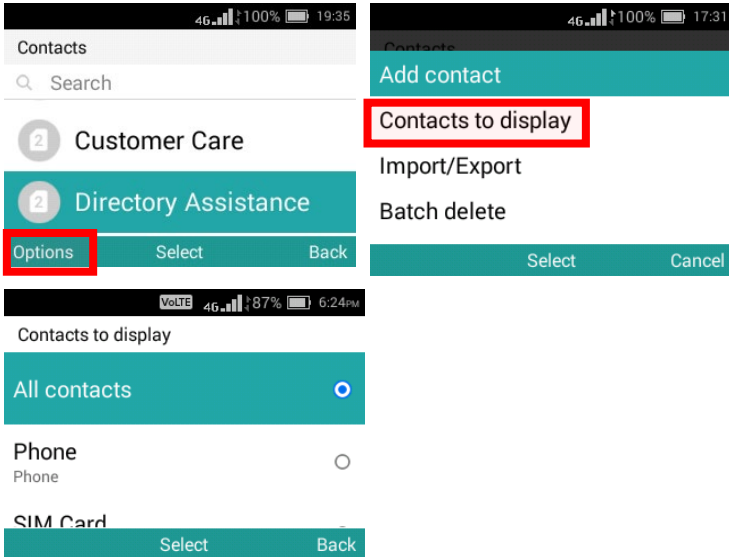

Import/Export contacts

To copy/import/export/share contacts, press the Options button and press the OK button on “Import/Export”.

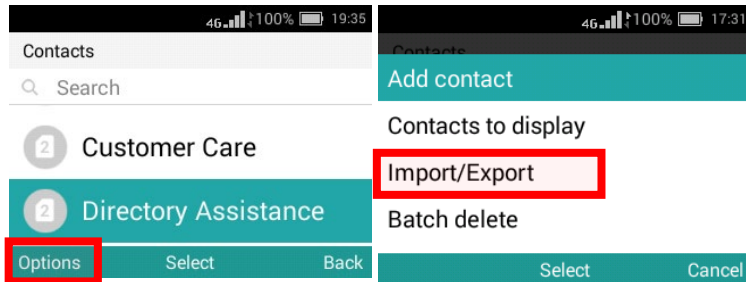

1. Copy to

To copy contacts between SIM card and phone's internal memory, select "Copy to" for the destination. Then select the contacts you want to copy by the OK button, and press the Options button to confirm copying.

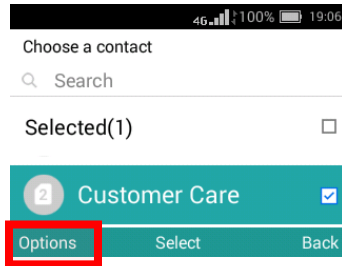
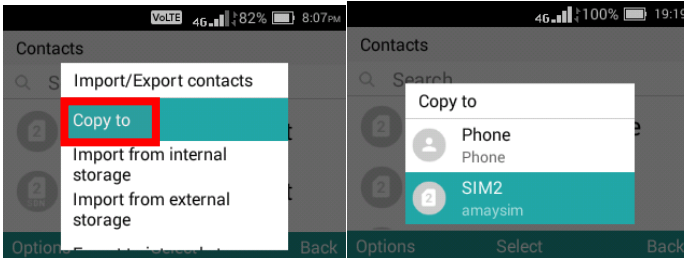

2. Import Contacts

Within Import, you can import contacts from your internal file system or external memory card to phone's internal memory. Select the contacts you want to copy by the OK button and press the Options button to confirm importing.

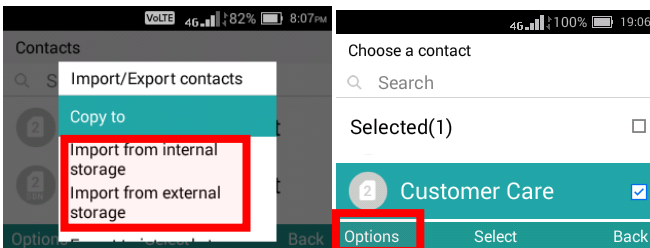

3. Export Contacts

Within Export, you can export contacts from the phone's internal memory to internal file system or external memory card. Select the contacts you want to copy by the OK button and press the Options button to confirm exporting.

Within Export, you can export your phones contacts onto your sim card or TF card. Choose where you want to export from and then press ok on next. Then choose where you want to copy the contacts to and then press ok on next. Now select which contacts you wish to copy using the OK key and then press the options button to complete.

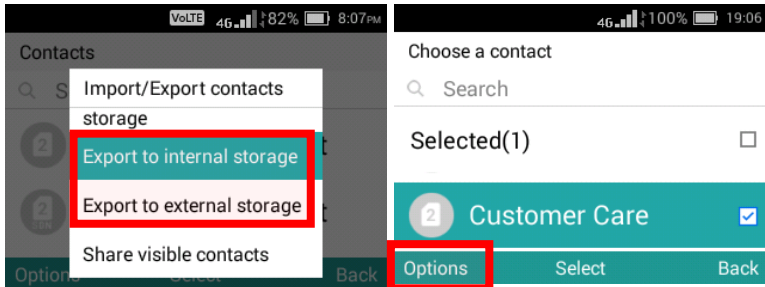

4. Share Contacts

To share contacts via Bluetooth or Messaging, select "Share visible contacts" and then Bluetooth or Messaging using the OK button. Then select the contacts you want to copy by using the OK button and press the Options button to confirm sharing.

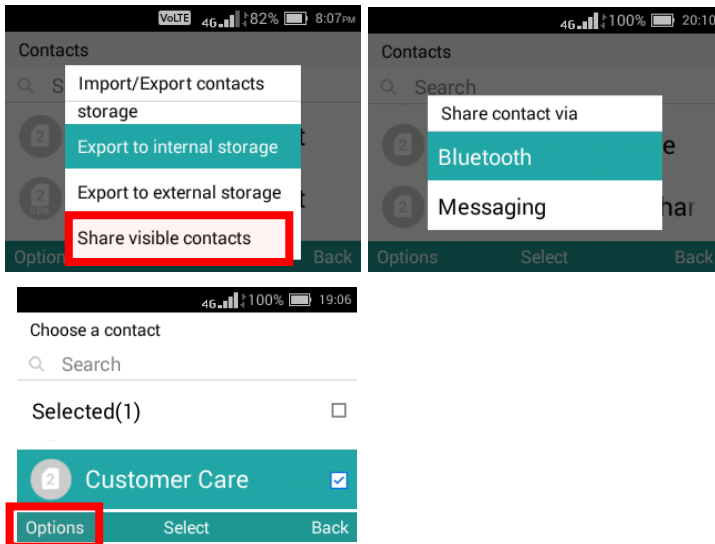

Batch Delete

To select multiple contacts to delete, press the Options button and press the OK button on “Batch Delete”. You can select the contacts you want to delete by using the OK button, and press the Options button to confirm deletion.

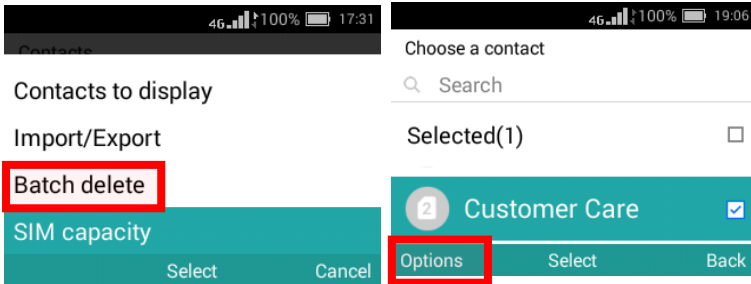

SIM capacity

To view how many contacts have been saved to the SIM cards, press the Options button and press the OK button on “SIM capacity”.

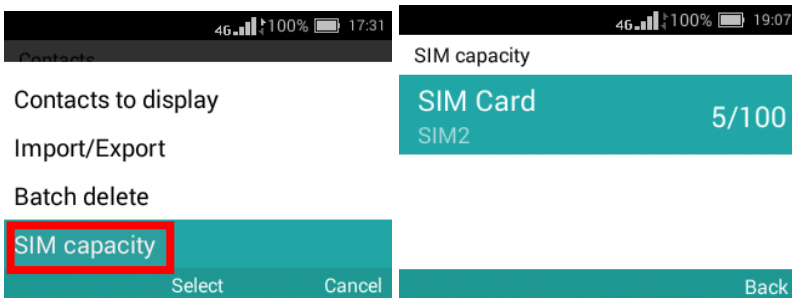

Messaging

To access SMS and MMS messages, press the OK button on the Messaging icon from the home screen.

Here you can view previous conversations and messages or create new messages to message your friends and family. Messages from the same contact or phone number will be grouped into one thread, so it is easy for you to follow conversations.

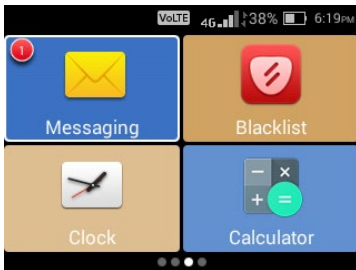

Creating a new message

1. In the Messaging app, press the Options Button to open the menu.
2. Then selecting "New message" by pressing the OK button

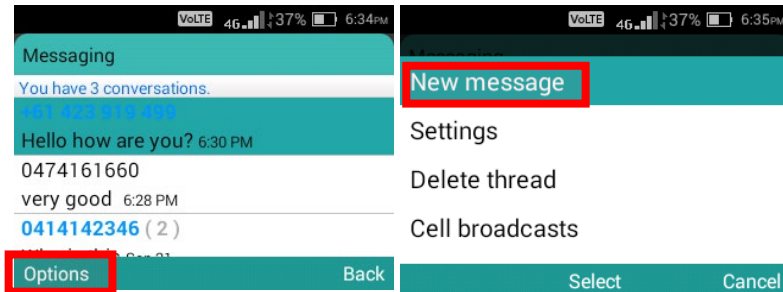

3. Type in the name or phone number of the person you wish to message using the keypad. Or select a contact from the Contacts by using the right cursor button to select the “Add recipient” icon.

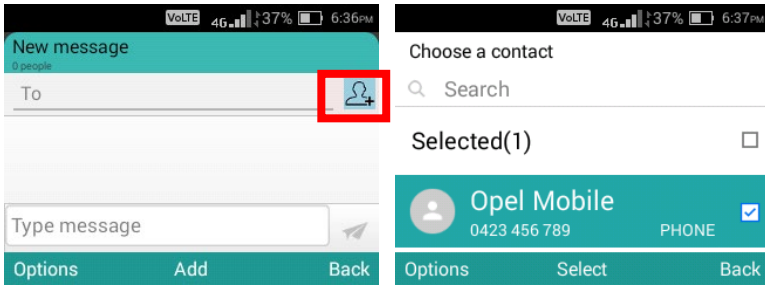

4. Then scroll down to type your message using the keypad.
5. To send the message, use the right cursor button to select the “Send” icon.

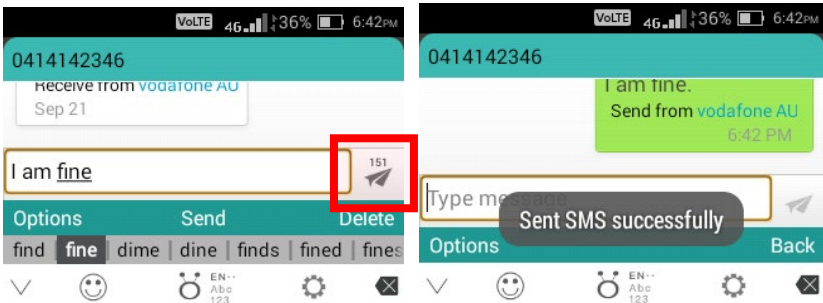

View messages

To view a new message or a previous conversation, press the OK button on the conversation you wish to view. Once opened you can scroll up and down the message conversation to read or view images that have been sent to you.

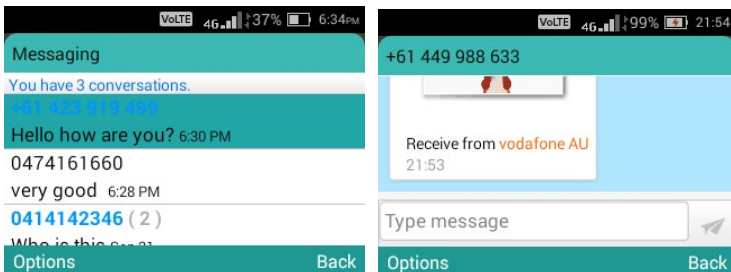

View the attachments of MMS messages

To view an image, video or audio of a MMS message that has been sent to you, open the message that contains the item, and then use cursor buttons to highlight the attachment and press the OK button to view it.

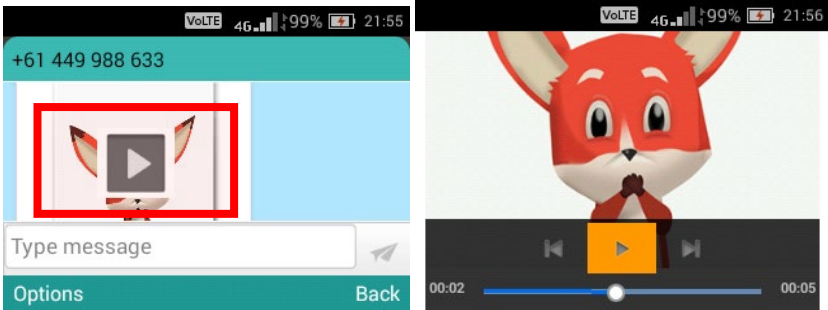

Reply messages

To reply to a message, scroll down to the “Type message” box then type the message using the keypad. Once complete use the right cursor button to select the “Send” icon.

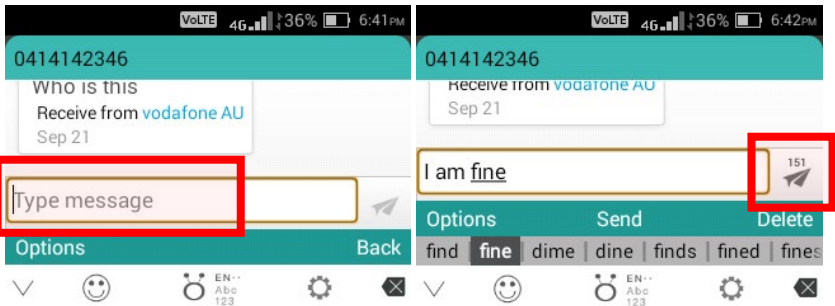

Forward a message

To forward a message, highlight the message using the cursor buttons and press the Options button to open the menu. Select “Forward” from the menu to forward

it to another contact. Once complete use the right cursor button to select the “Send” icon.

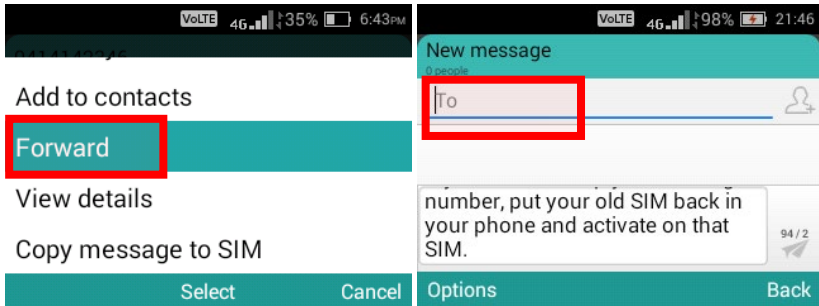

Delete messages

1. To delete messages from the same sender, while viewing the message thread, press the Options button and use the OK button to select “Delete”. You can select multiple messages to delete by the OK button, and press the Options button to confirm deletion.

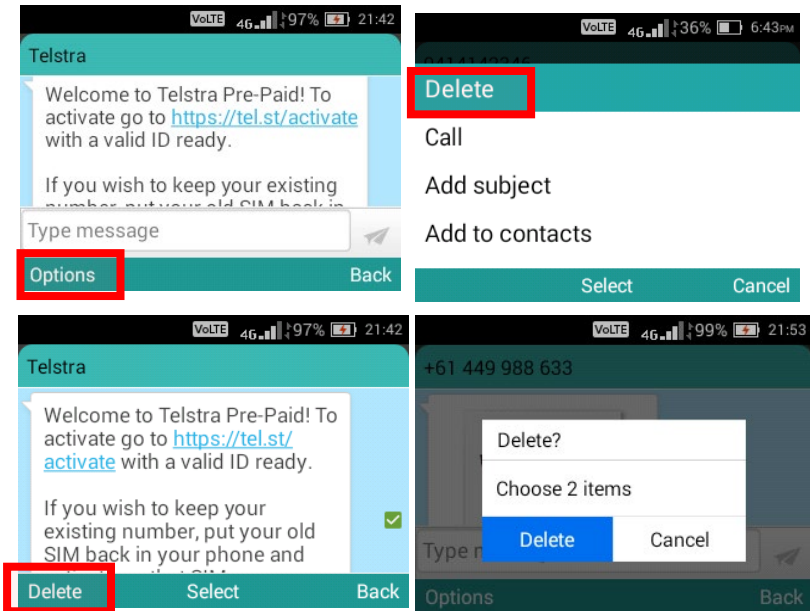

- To delete multiple message threads, while in the main interface of Messaging, press the Options button and use the OK button to select “Batch Delete”. You can select multiple message threads to delete by the OK button and press the Options button to confirm deletion.

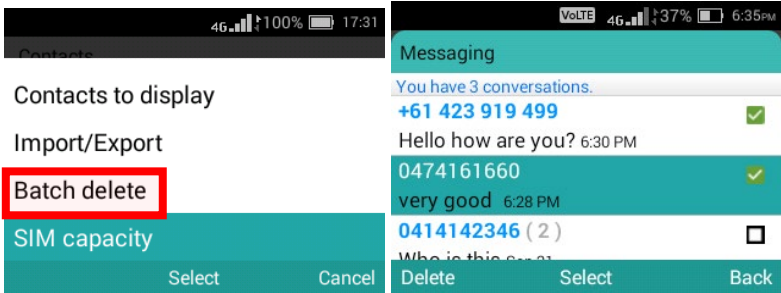

Call the sender while viewing a message

To call the sender, highlight the message using the cursor buttons and press the Options button to open the menu. Select “Call” from the menu to call the sender.

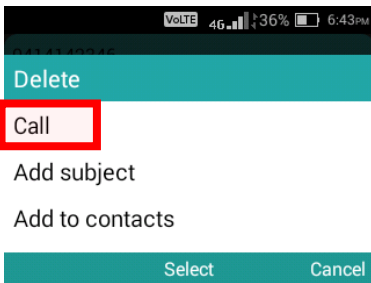

Copy message to SIM

To copy a SMS message to SIM card, while viewing a SMS message, press the Options button and use the OK button to select “Copy message to SIM”.

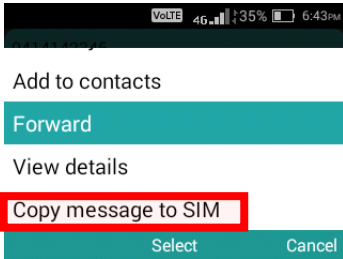

To view SMS messages in SIM cards, while in the main interface of Messaging, press the Options button and use the OK button to select “Messages in SIM”.

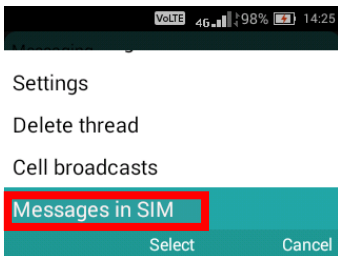

Cell Broadcasts

To change cell broadcasts settings, while in the main interface of Messaging, press the Options button and use the OK button to select “Cell broadcasts”. Then press the Options button again to change the settings.

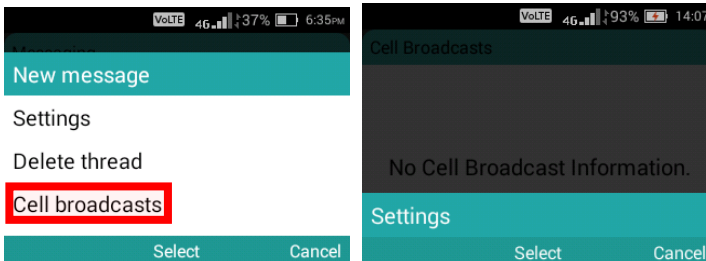

1. **SIM specific cell broadcasts** – Select SIM1 or SIM2 to add or remove operator’s cell broadcast channels.

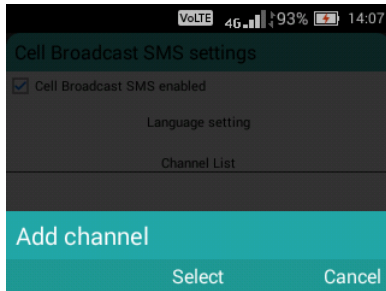
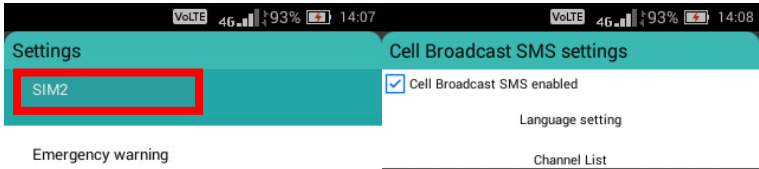

2. **Emergency warning broadcasts** – Select Emergency warning to enable or disable government mandatory emergency broadcasts.

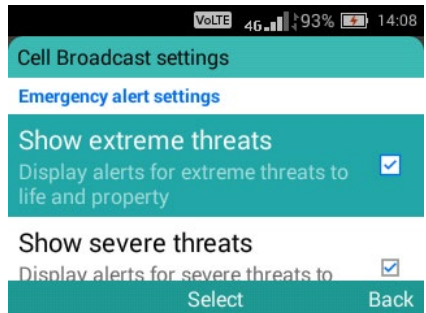
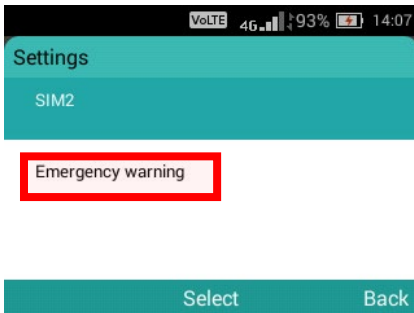

Message settings

To open message settings, while in the main interface of Messaging, press the Options button and use the OK button to select “Settings”.

1. **General settings** – You can change the general settings like font size, auto-delete old messages and their limits, SMS/MMS creation settings, signature, notification options.

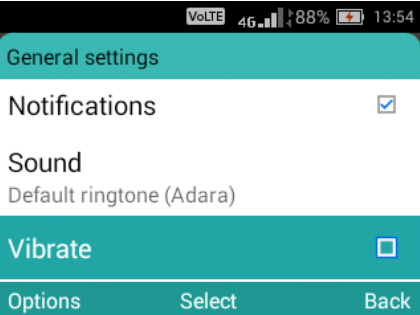
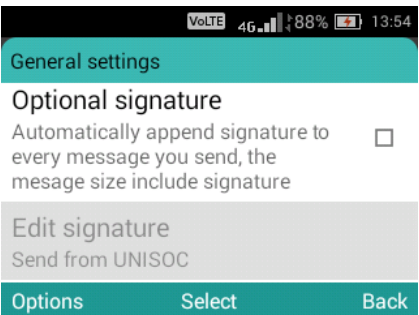
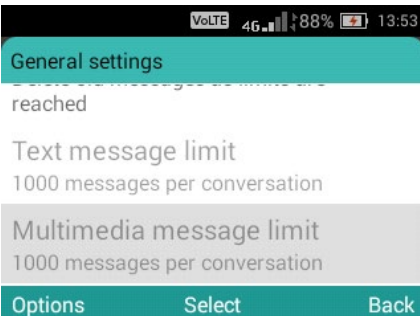
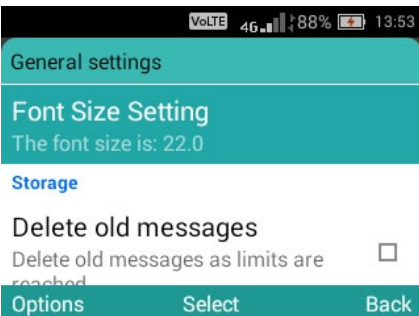
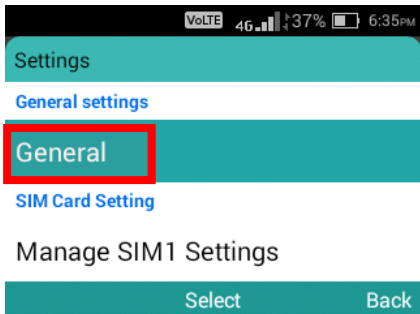
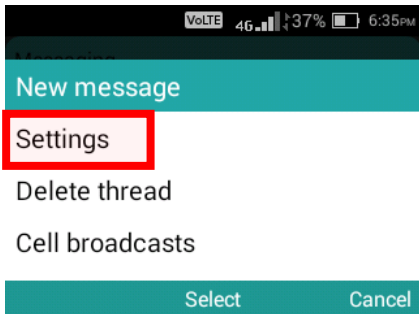

2. **SIM card settings** – You also can change SIM card specific settings like delivery/read reports, message validity, auto-download MMS, auto-save SMS on SIM and SMS centre.

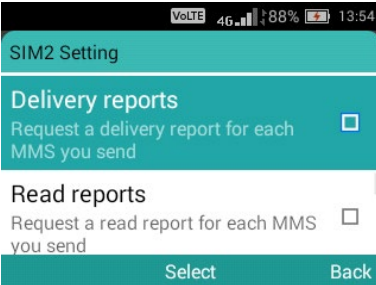
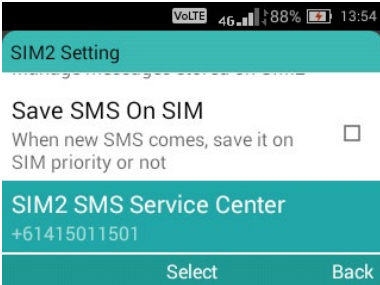
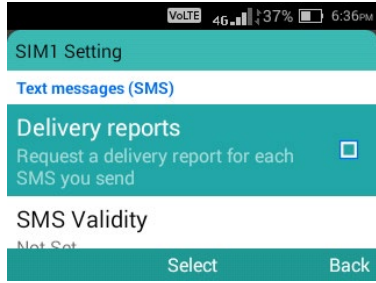
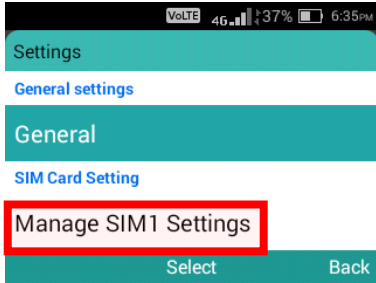

Blacklist

To access Blacklist, press the OK button on the Blacklist icon from the home screen. In the Blacklist app you can add phone numbers so that this number is blocked and cannot call or send messages to you.

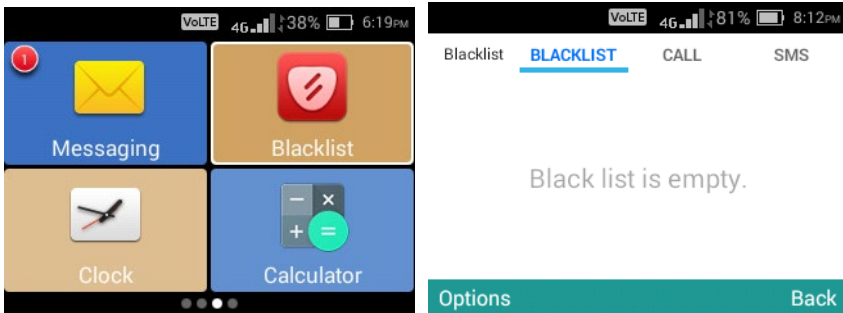

Add to blacklist

Press the Options button to select “Add new blacklisted number” and then type in the phone number to be blocked. You can select whether to block phone calls or SMS.

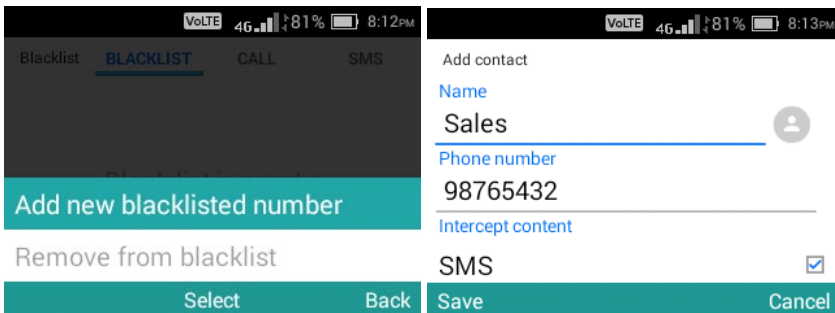

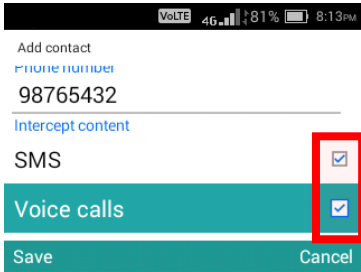

Remove from blacklist

Press the Options button to select “Remove from blacklist” and then use the OK button to select the phone numbers for removal. Or first highlight the phone number for removal, then press the OK button to select “Delete” to remove it.

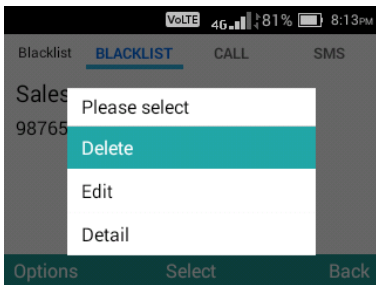

Check blocked calls and SMS

Use the left and right cursor buttons to select “Call” and “SMS” to check the blocked calls and SMS history.

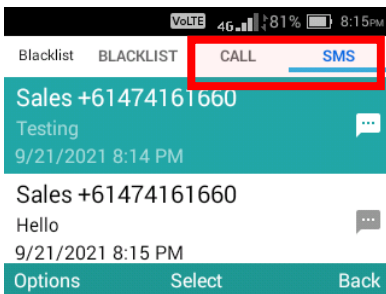

Clock

To access Clock, press the OK button on the Clock icon from the home screen. In the Clock app you can set alarms, view world clock, set timer and use the stopwatch using the left and right cursor buttons.

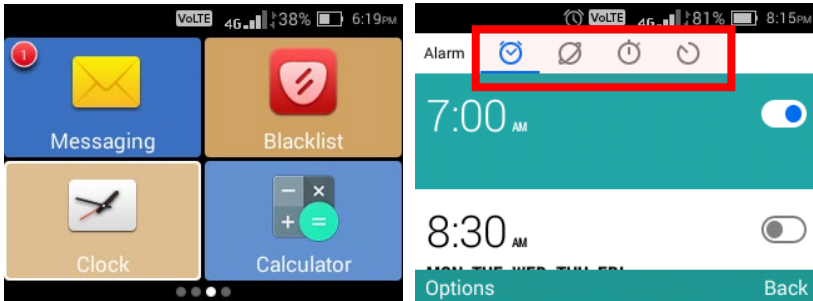

Alarm Clock

1. Scroll across to alarm clock, here you can set alarms to wake you in the morning or for other events or reminders. You can select OK on a current alarm selection to turn it on.

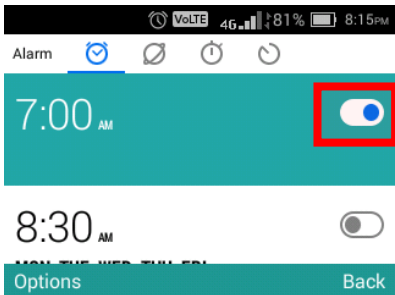

2. Press the Options button to add, delete, edit or change the alarm settings.

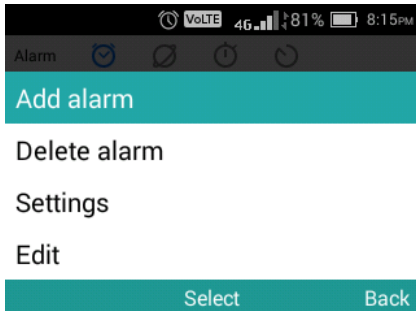

3. To add an alarm, press the Options button and then press the OK button on Add to adjust the alarm time.
4. To delete an alarm, highlight the alarm you want to delete then press the Options button and press the OK button on Delete and confirm deletion.
5. To edit an existing alarm, highlight the alarm you want to edit then press the Options button and press the OK button on Edit.
6. Alarm Settings – within alarm settings you can adjust the snooze time length.

World Clock

To add cities to your world clock list, press the Options button and select Add World clock with the OK button. Then type the city's name or scroll down using the cursor buttons until you find the cities you wish to include in your world clock, then press the OK button to add it.

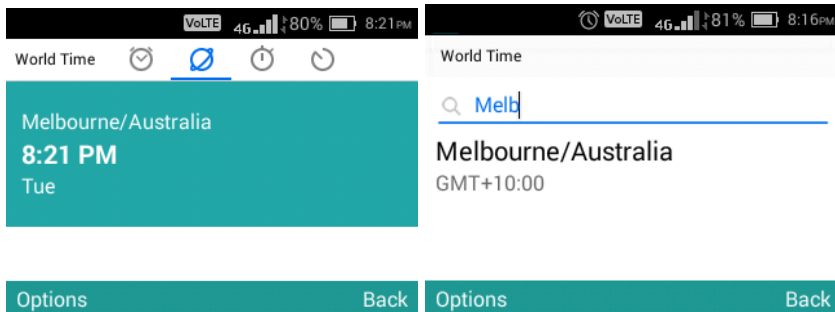

Stopwatch

Press the OK button to start the stopwatch. To add lap times, press the Options button. You can pause the timer and start again by pressing the OK button. To delete a lap, stop the stopwatch and then highlight the lap and press the Options button to reset.

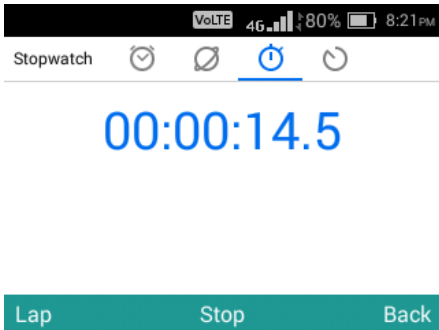

Timer

Scroll across to the timer function, using the keypad number, type the time you wish to count down. For example, to do 1 Minute, type in 1, 0, 0. Then press the OK button on start to activate the timer, an alarm will sound once the time is up.

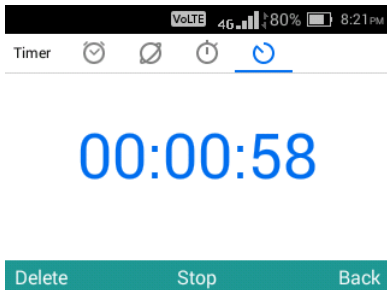

Calculator

This is just like any normal calculator. To access Calculator, press the OK button on the Calculator icon from the home screen.

Press the numbers on the keypad and use the Left/Right/Up/Down cursor and the OK button for the calculations. The Star * button is the +/- selection, the Hash # button is a decimal point, and the Options button is percentage.

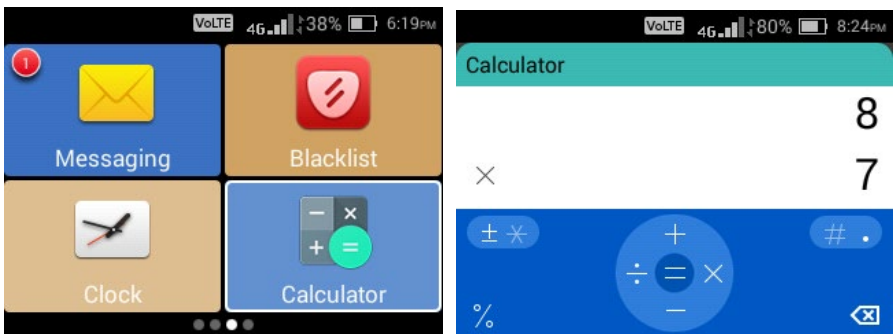

Sound Recorder

To access Sound Recorder, press the OK button on the Sound Recorder icon from the home screen.

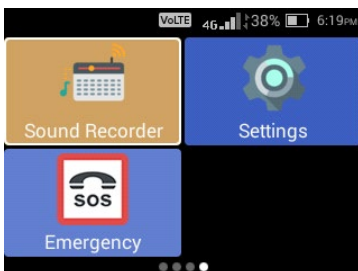

Press OK button to start or pause the recording and press the Options button to stop.

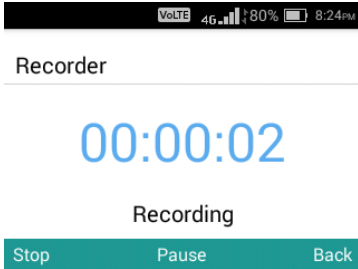

When the recording is stopped, press the Options button to open to the recording file list. Press the OK button on the highlighted file to play it. Press the Options button to select “Delete” or “Rename” the recorded sounds files, changing the storage location to memory card, or changing the recording quality.

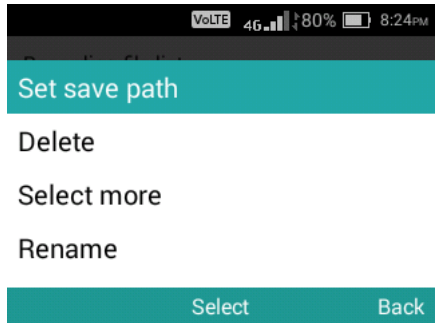
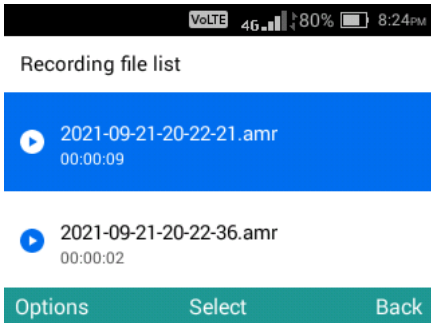

SOS – Emergency Call

The SOS feature is designed for people who may need the function to easily contact their family or close friends if they are ever in need of help.

When the SOS is activated, it will send a text message to all your SOS contacts with a predetermined customisable message. After it sends out the text messages it will then attempt to ring your SOS contacts until someone answers the call.

To activate the SOS feature, press the SOS button 3 times until you hear the SOS siren. If you want to cancel or end the SOS feature, press the red End Call key.

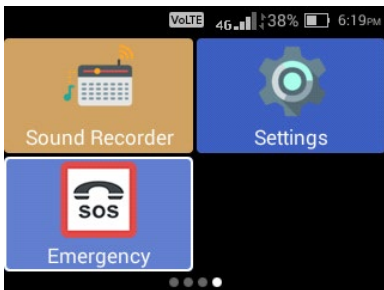

How to setup the SOS function

1. Enable the SOS feature by pressing the OK button on “Emergency Call”, when the toggle is blue it means this feature is turned on.

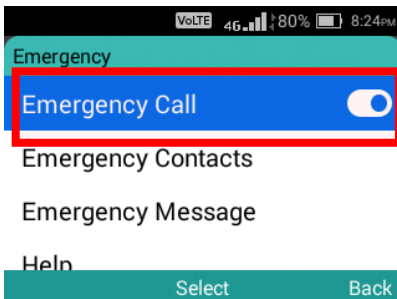

2. Add SOS Emergency Contacts by scrolling down to “Emergency Contacts” and pressing the OK button. You can add up to 5 SOS contacts. Press the OK button on an empty contact spot and type in their phone number. Once completed press the Options button and then select OK to save.

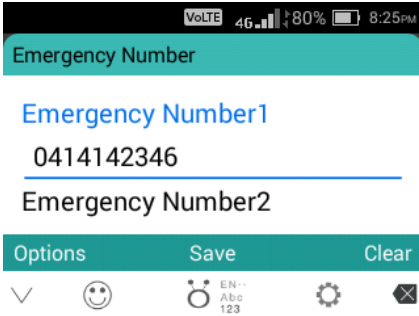

Scroll down to “Emergency Message” if you wish to modify the default SOS message. Once completed press the OK button to save.

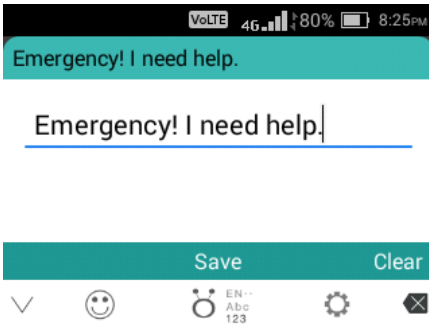

PLEASE NOTE:

This device is not intended to be a life saving device; If you are in a life-threatening medical emergency, we recommend you call emergency 000 immediately.

Settings

Under settings you can adjust the phone settings, like SIM card manager, mobile network, Wi-Fi, Bluetooth, display settings, sound settings, speed dial, storage options, security settings, language and factory reset.

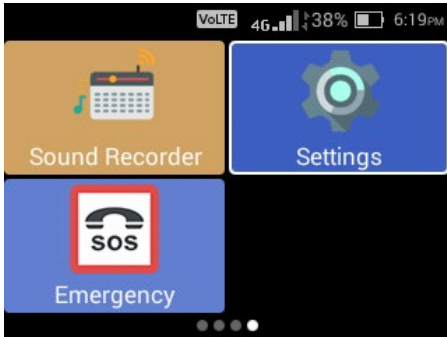

Settings – Connections

Here you can select Wi-Fi options, hotspot and tethering, Bluetooth, mobile network settings.

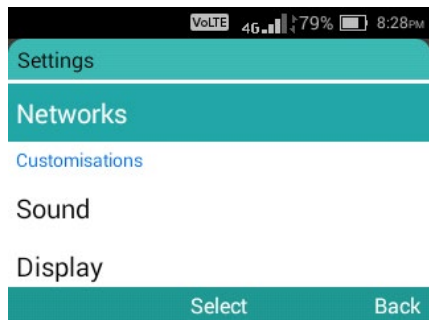
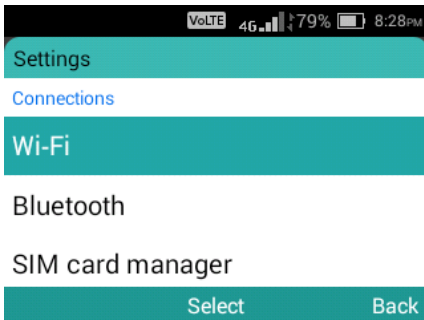

1. **Wi-Fi** – Press the OK button on Wi-Fi to open the Wi-Fi menu. Press the OK button on on/off to turn the Wi-Fi option on or off. To connect to Wi-Fi network,

highlight and press the OK button on the network name you wish to connect to, most will ask for the password to connect (Check your Wi-Fi router for the password). Once it connects it will say connected.

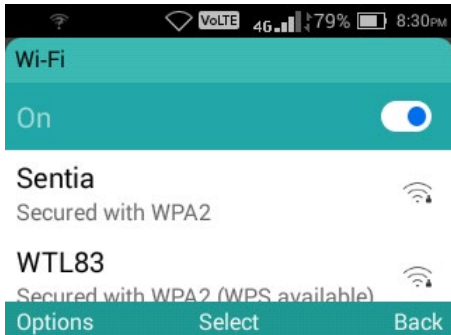

2. **Bluetooth** – Press the OK button on Bluetooth and turn Bluetooth on by pressing the OK button again. Press the OK button on an available device to pair up. Once paired it will say connected.

Please note: Some devices will require passwords to connect, ensure you read the instructions on the other device to connect via Bluetooth. TIP: some Bluetooth passwords are 1234 or 0000.

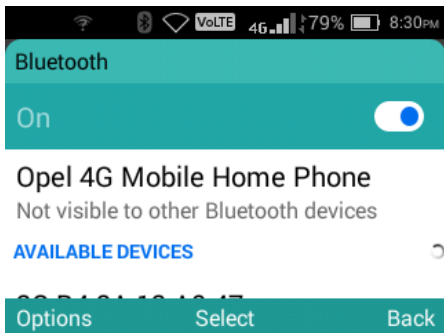

3. **SIM Card Manager** – Here you can configure the dual SIM card settings, by turning them on or off, selecting which SIM card for mobile data, call and SMS. You also can specify which SIM card is the primary card, and whether you want to use the same SIM card to reply messages.

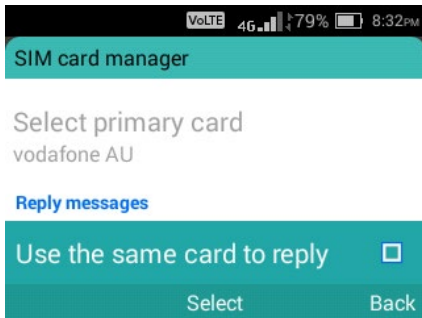
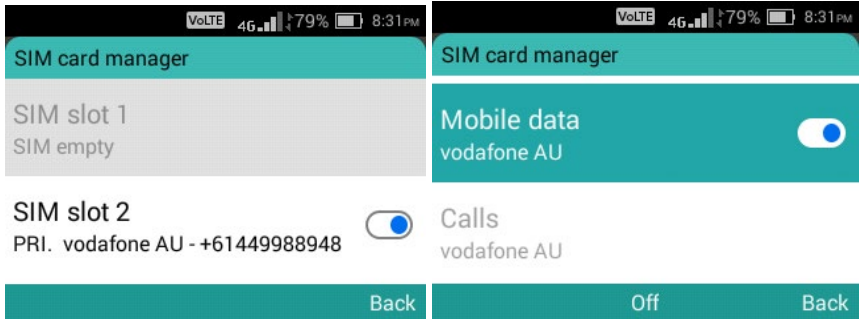

4. **Mobile Network settings** – Here you can turn on or off Wi-Fi hotspot, toggle data roaming, choose preferred network type, turn on or off VoLTE and Wi-Fi Calling, and change Access Point Names (APN).

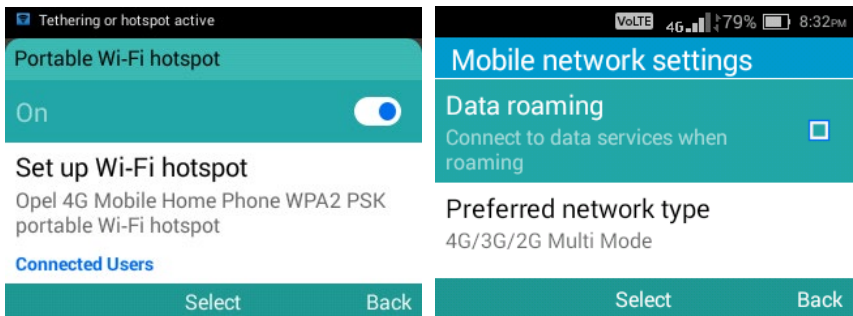

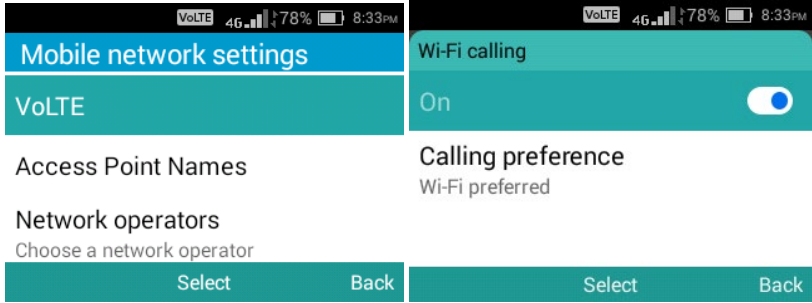

Settings – Customisations

Here you can change the settings of Sound, Display, Date and Time, Post-dialling delay, Speed Dial, Language and Input.

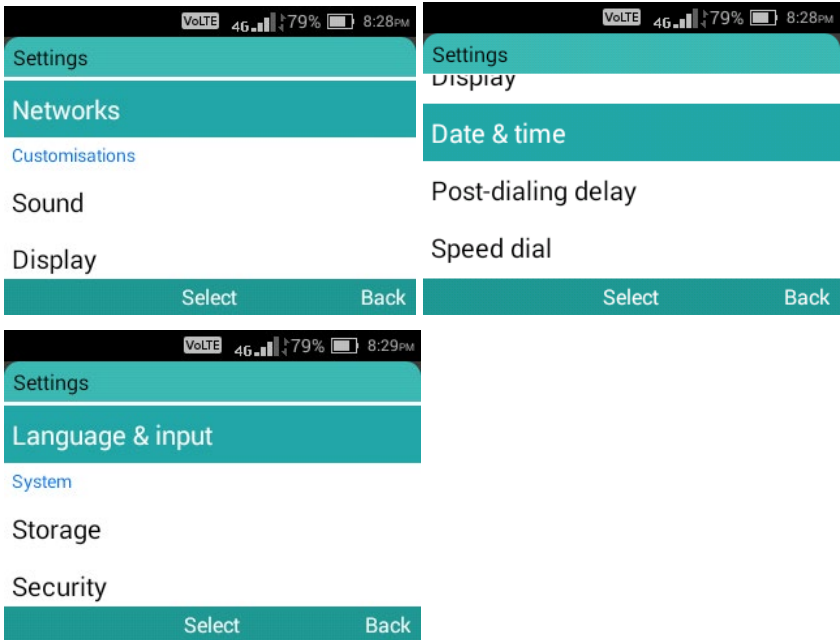

Settings – Sound

1. **Sound profiles** – Here you can add or change the Profiles, Volume, Ringtones, notification tone, and keypad tap sounds.
Press the “OK” button to activate or edit the highlighted sound profile, or press the OK button to add a new Sound Profile.
2. **Volume** – Use the cursor buttons to adjust the volume of different alert and media types.

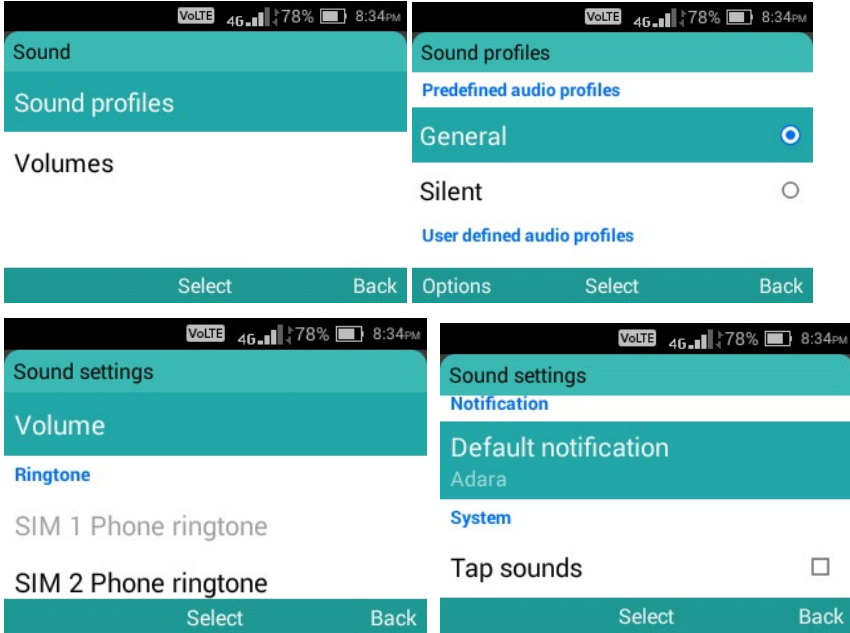

Settings – Display

1. **Brightness** – Here you can adjust the brightness level of the phones screen. Press the OK button and then the left and right cursor buttons to adjust the screens brightness level. Press Back button to save.
2. **Sleep** – Here you can adjust the screen timeout timer. Press the OK button and then highlight the preferred timer and press the OK button to save.

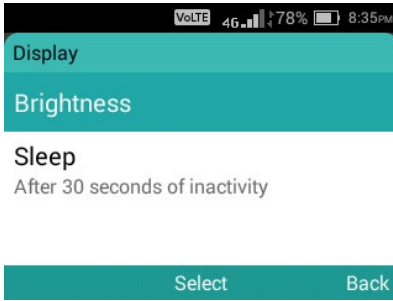

Settings – Date & Time

Here you can turn automatic time and date settings on and off, turn automatic time zone setting on or off, manually set the date, time, time zone and change the time format. Press the OK button on the functions you wish to change.

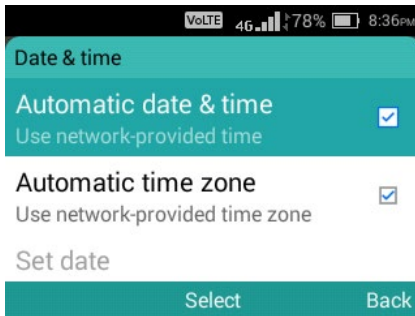

Settings – Post-dialling delay

Here you can change the dialling delay timer. Select OFF to prevent the phone to start dialling while you are keying in the phone number. You can set the delay timer from 3-seconds to 9-seconds before the phone will dial the phone number you have entered in.

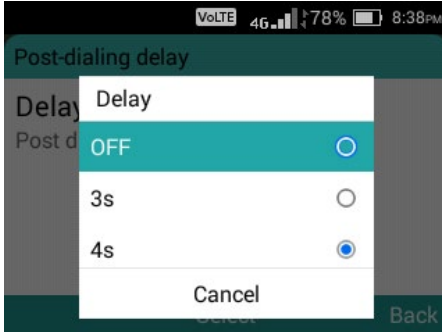

Settings – Speed Dial

Speed Dial is a quick and easy way to call the people that you may contact on a regular basis. Up to 8 contact shortcuts can be added to Speed Dial.

To add a phone number to speed dial, highlight the empty slot using the up and down cursor buttons, then press the OK button to choose an existing contact from your phonebook.

To remove a phone number from speed dial, highlight it and press and hold down the OK button to remove it.

To call any of your Speed Dial contacts from the home screen, press and hold down the respective keypad number for 3 seconds, it will then call that number.

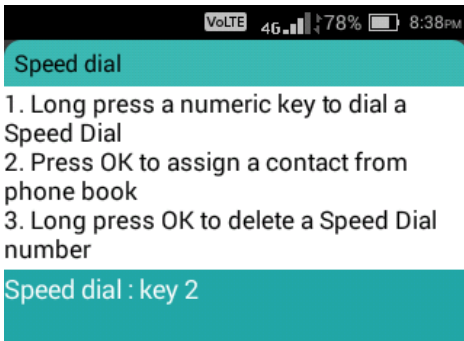

Settings – Language & Input

Here you can change the language on your device. Press the OK button on languages and highlight the language you wish to use then press the OK button again.

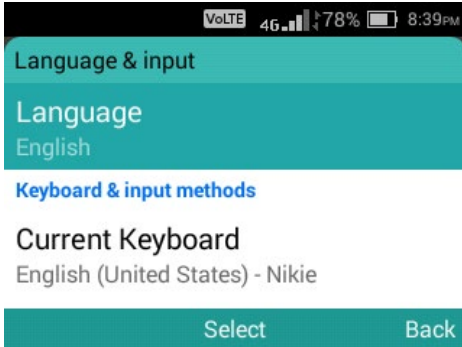

Settings – System

Here you can change the settings of Storage, change Security details, Reset the device and perform any new Wireless Updates.

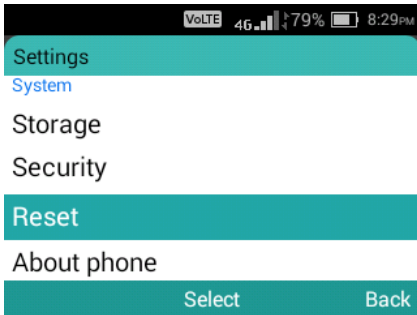

Settings – Storage

In the storage menu, you can view all files that are stored on your device and how much storage they are taking up on your device.

To view files in a storage location, highlight the item and press the OK button to view the details.

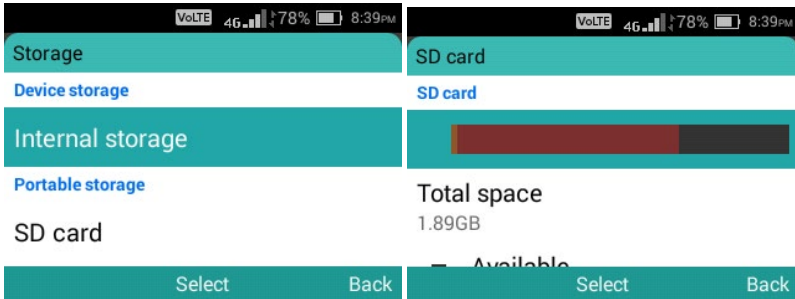

Settings – Security

Here you can turn SIM Card lock on or off. Press the OK button and type in the password to turn this feature on and off. **Please note your SIM card provider would have provided the SIM card lock password when you originally received the SIM card.**

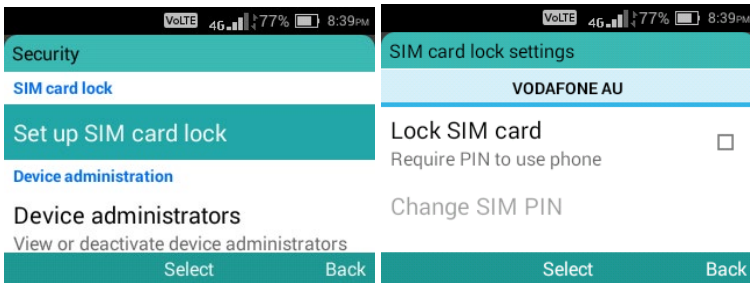

Settings – Reset

Here you can Factory Reset your device by erasing all the data and bring the phone back to the original factory/default settings.

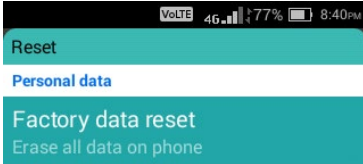

Please Note: Erase all data on phone (Factory Reset) cannot be undone once selected. This will reset and delete all information/data stored on this device.

Settings – About Phone

Here you can perform wireless updates and view the status of the device (Battery status, Battery level, SIM Status, IMEI Information, IP Address, Wi-Fi MAC address, Bluetooth address, Serial number and Up Time, model number, software version of the phone.

Wireless Update – To perform a wireless update press the OK button on “Check for updates”. If there are any updates the device will prompt you to update to the latest version. **(Mobile data or Wi-Fi connection is required)**

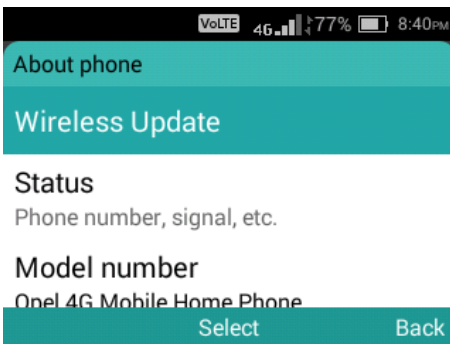

Troubleshooting and support

If you are experiencing difficulties with your phone, please go through the following troubleshoots:

The Phone will not power on

1. Ensure the battery is inserted correctly.
2. Ensure the phone is connected to the power adapter.
3. Ensure you have removed the battery sticker from the gold connection pins.
4. Ensure you are pressing and holding the power button for 5 seconds to turn the phone on.

The phone is asking for a PUK code

1. This means you have input the incorrect password 3 times or more. Contact your network provider to retrieve your PUK code to unlock your phone. Only your network provider can help unlock your SIM.

SIM card error or no SIM card

1. Ensure you have inserted the SIM card correctly and are using the correct size SIM card. Follow instructions in the quick set up guide for installing the SIM card.
2. Your SIM card may be damaged or dirty. Ensure you replace your SIM with your network provider if this error occurs.

Failure to connect to the network

1. Your network signal may be weak or out of range. Contact your network provider or try the phone in a different location to check your signal.
2. Your SIM card may be damaged, invalid or has no credit. Contact your network provider for support.

3. Ensure you have enough credit on your network provider's account. Contact your network provider for support.

Failure to make an outgoing call

1. Ensure you have entered the correct phone number you wish to dial.
2. Ensure you have enough credit on your network provider's account. Contact your network provider for support.
3. Your signal strength may be weak. Check your signal strength and contact your network provider.

Cannot receive calls

1. Ensure your phone is switched on.
2. Ensure you have enough signal strength to receive calls.
3. Ensure you do not have the phone in flight mode.
4. Ensure your SIM card is installed correctly.

Cannot hear anyone on the call

1. Ensure your call volume is adjusted to your requirements. Using the volume buttons on the phone's keypad.
2. Ensure you have sufficient signal strength.

The other party cannot hear you on the call

1. Ensure you have lifted the handset up and place the earpiece near to your ears, or pressed the speakerphone button for loud speaker mode.
2. Ensure your hand or fingers are not covering the microphone.
3. Ensure you are speaking directly into the microphone.
4. Ensure you have not muted the call.
5. Ensure the other party has their volume turned up to their desired level.

Phone won't charge

1. Ensure the power plug is inserted in the wall socket correctly and the wall switch is turned on.

2. Ensure the wall power socket is working by testing another device or a separate power socket.
3. Ensure you have inserted the Micro USB cord into the phone correctly.
4. Ensure there is no dirt or dust accumulated in the phones power socket.
5. Ensure you have left the phone on charge for at least 10 minutes as the battery may have run out of charge completely.

Phone won't connect via Bluetooth

1. Ensure you have turned on and activated the Bluetooth setting.
2. Ensure you follow the Bluetooth instructions above.
3. Ensure the other device has Bluetooth enabled.
4. Your Bluetooth device may be too far away from the other device to connect. Ensure you are within range of this device to connect.

Phone won't connect to Wi-Fi

1. Ensure you have turned on and activated Wi-Fi on your phone. See Wi-Fi guide in the manual.
2. Ensure the Wi-Fi you are connecting to is working.
3. Your device may be too far away from the Wi-Fi Router. Ensure you are within range of this device to connect



4G Mobile HomePhone Operator's Manual